

Errata Sheet

AASHTO/AWS D1.5M/D1.5:2008, *Bridge Welding Code*

The following Erratum has been identified and incorporated into the current reprint of this document.

Page 319—Figure C-3.5 (A) & (B) Illustration of Camber Tolerances for Steel Beams—For sketches (A) & (B) the line depicting the “Detailed Camber Shape” was corrected and made bolder than the line depicting “Actual Camber of the Steel” for additional clarity. Please see corrected figure below:

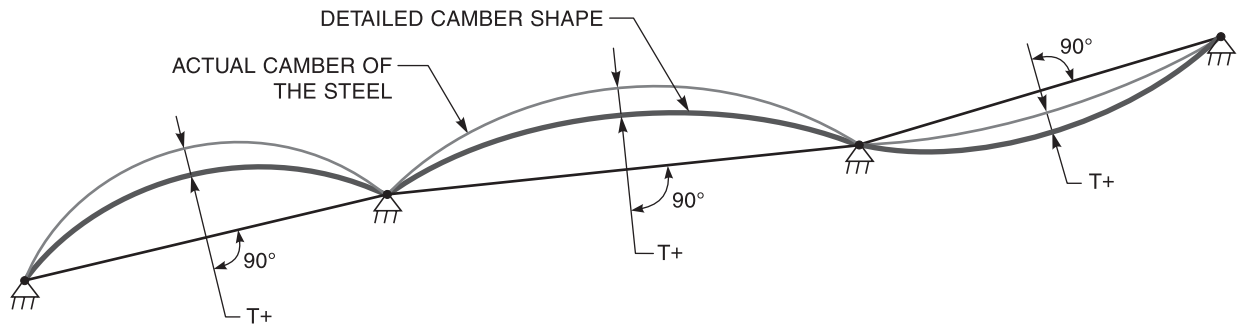

PLUS CAMBER TOLERANCE (T_+) APPLIES WHEN THE ACTUAL CAMBER OF THE STEEL IS ABOVE THE DETAILED CAMBER SHAPE. THIS TOLERANCE IS MEASURED PERPENDICULAR TO A STRAIGHT LINE BETWEEN THE SUPPORTS OF EACH SPAN.

(A) PLUS CAMBER TOLERANCE

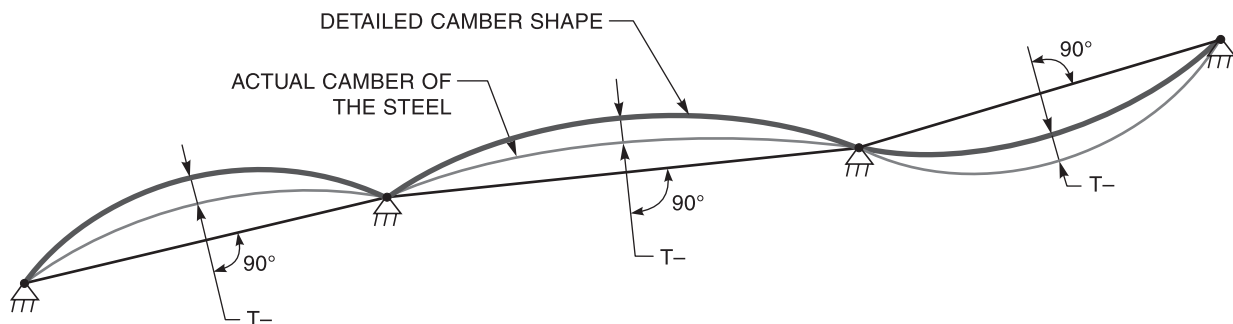

MINUS CAMBER TOLERANCE (T_-) APPLIES WHEN THE ACTUAL CAMBER OF THE STEEL IS BELOW THE DETAILED CAMBER SHAPE. THIS TOLERANCE IS MEASURED PERPENDICULAR TO A STRAIGHT LINE BETWEEN THE SUPPORTS OF EACH SPAN.

(B) MINUS CAMBER TOLERANCE

Figure C-3.5—Illustration of Camber Tolerances for Steel Beams

ERRATA SHEET

AASHTO/AWS D1.5M/D1.5:2008, *Bridge Welding Code*

The following Erratum have been identified and incorporated into the current reprint of this document.

Page 89 - Clause 5.10.2 - Delete paragraph after the "Fillet Weld Properties" title so that no verbiage exists in the clause.

Page 241 - Clause H2, First Paragraph - Incorrect reference. Change reference from "Annex Table G.1" to "Annex Table H.1."

Page 262 – Form L-3 Procedure Qualification Records (PQR) for Qualification, Pretest, and Verification Results – Change “Maximum Size Single Pass” to “Minimum Size Multiple Pass” under Macroetch row.