

ITEM	DESCRIPTION	QTY.	REMARKS
A	10mm [3/8"] x 75mm [3"] x 180mm [7"]	2	30° Bevel one edge
B	16mm [5/8"] x 75mm [3"] x 180mm [7"]	2	30° Bevel one edge
C	4 Inch Sch 80 Pipe X 4" 30° bevel one end	2	30° Bevel one end

Designed by	Drawn By Nick Peterson	Date June 1, 2007	ISO A	Scale NONE
Weld-Off at the AWS Welding Show Las Vegas, NV 2008			Name PROJECT TASK FILLET WELD A & B	Revision 0
			Trade 10 WELDING	Sheet 1 of 1

TACK WELDS NOT GREATER THAN 25mm LONG.
1 ON EACH END

Test Pieces 10mm X 100mm X 225mm

Fillet Weld A _____ Fillet Weld B _____

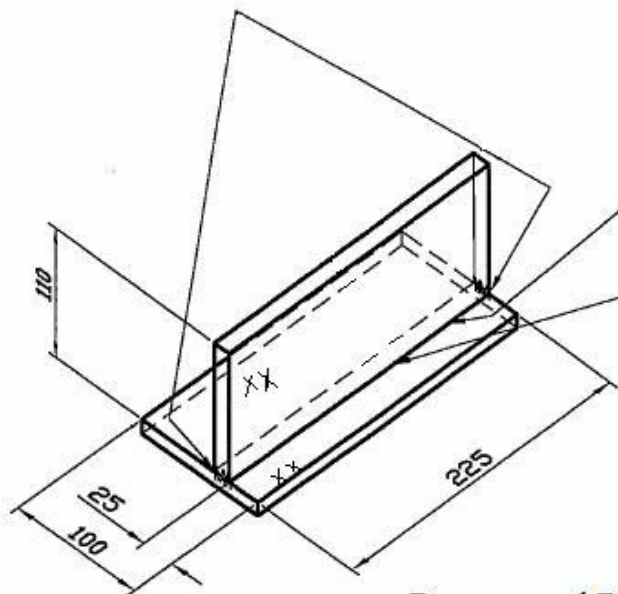

2F and 4F FILLET WELD
SHALL BE MADE IN
3 RUNS

EACH RUN OF WELD TO BE
STOPPED & RESTARTED
WITHIN THE CENTRAL 50mm

1F and 3F FILLET WELD SHALL
BE MADE WITH A MIN
OF 2 RUNS

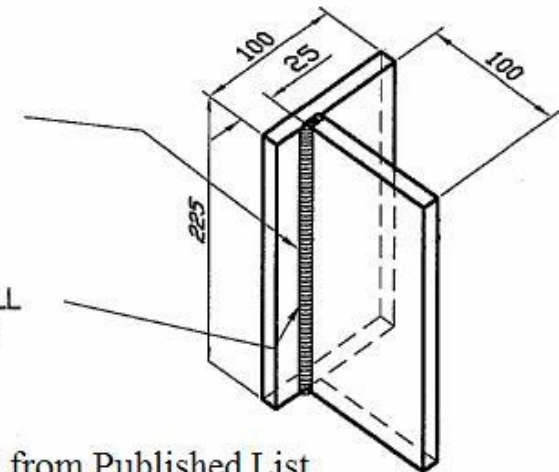

Stamp ID # and
Date Each Test
Piece at XX's

Process and Position will be Randomly Selected from Published List

All Fillet Welds will be 10mm in size +1mm or -1mm