

AMERICAN WELDING SOCIETY
WELDING INSPECTOR EXAMINATION

Part B

EXAMINATION BOOK OF SPECIFICATIONS

TABLE OF CONTENTS

Appendices

	<u>Page No.</u>
I. Welding Procedure Qualification Record (PQR)	1
II-A. Performance Qualification Test Record	2
II-B. Welder Performance Qualification Record (Example)	3
III. Prequalified Complete Joint Penetration Groove Welded Joints	4
IV. Pipe Schedules	5
V. Acceptable and Unacceptable Weld Profiles	6
VI. Weld Profile Acceptance Description	7
VII. Visual Weld Inspection Acceptance Criteria	8
VIII. Test Results Required, Guided Bends	9
IX. Weld Metal Analysis	10
X. Electrode Groups	11
XI. Welder Qualification Test Requirements	13
XII. Fillet Procedure Qualification Requirements	15
XIII. Groove Procedure Qualification Requirements	16
XIV. Prequalified Base Metal—Filler Metal Combinations for Matching Strength	17
XV. Minimum Preheat and Interpass Temperature	20
XVI. Radiographic Testing	22
XVII. Face and Root Bend Specimens	27

Conversions and Calculations

The International System of Units (SI) makes use of conversion factors and metric prefixes. Use the following tables:

Table of SI Conversions

PROPERTY	U.S. CUSTOMARY UNITS	SI UNITS	
	<i>To convert from</i>	<i>To</i>	<i>Multiply by</i>
force	pound-force (lbf)	newton (N)	4.5
	kip (1000 lbf)	newton	4450
linear dimension	inch (in)	millimeter (mm)	25.4
tensile strength	pounds per square inch (psi)	pascal (Pa)	6895
	(psi)	kilopascal (kPa)	6.89
	(psi)	megapascal (MPa)	0.00689
mass	pound mass (avdp)	kilogram	0.454
angle, plane	degree (angular) (°)	radian (rad)	0.0175
flow rate	cubic feet per hour (ft ³ /hr)	liters per minute (L/min)	0.472
heat input	joules per inch (J/in)	joules per meter (J/m)	39.4
travel speed, wire	inches per minute (in/min)	millimeter per second (mm/s)	0.423
temperature	degree Fahrenheit (°F)	degree Celsius (°C)	°C = (°F – 32)/1.8

Table of SI Prefixes

EXPONENTIAL EXPRESSION	MULTIPLICATION FACTOR	PREFIX	SYMBOL
10 ⁹	1 000 000 000	giga	G
10 ⁶	1 000 000	mega	M
10 ³	1 000	kilo	k
10 ⁻³	0.001	milli	m
10 ⁻⁶	0.000 001	micro	μ
10 ⁻⁹	0.000 000 001	nano	n

Formulas

PROPERTY	FORMULA
ultimate tensile strength (uts)	uts = maximum load/original cross-sectional area
cross-sectional area (csa)	csa = $\pi D^2/4$ (for circle) csa = width × thickness (for square or rectangle)
temperature	degree Fahrenheit (°F) degree Celsius (°C) °C = (°F – 32)/1.8
	degree Celsius (°C) degree Fahrenheit (°F) °F = 1.8 × °C + 32

**This book is for examination purposes only.
It is not a working set of specifications nor a code.**

**The information contained herein may not match
the current editions of the referenced documents.**

Do not write in this book.

APPENDIX I

WELDING PROCEDURE QUALIFICATION RECORD (PQR)

PROCEDURE SPECIFICATION

Material specification _____ [1]
 Welding process _____ [2]
 Manual, semiautomatic, automatic: _____ [3]
 Position of welding _____ [4]

Filler metal specification _____ [5]
 Filler metal classification _____ [6]
 Weld metal analysis _____ [7]
 Shielding gas _____ [8]
 Flow rate _____ [9]
 Single or multiple pass _____ [10]
 Single or multiple arc _____ [11]
 Welding current _____ [12]
 Welding progression _____ [13]
 Preheat temperature _____ [14]
 Welder's ID _____ [15]
 Welder's name _____ [16]

GROOVE WELD TEST RESULTS

Tensile Strength, psi

1. _____ [24]
 2. _____ [25]

Guided-Bend Tests (2 root-, 2 face-, or 4 side-bends)

Root	Face	Side
1. _____ [26]	1. _____ [28]	1. _____ [30]
2. _____ [27]	2. _____ [29]	2. _____ [31]
		3. _____ [32]
		4. _____ [33]

Radiographic-Ultrasonic Examination

RT Report No: _____ [34]
 UT Report No: _____ [35]

VISUAL INSPECTION RESULTS

Appearance _____ [17]
 Undercut _____ [18]
 Piping porosity _____ [19]

FILLET WELD TEST RESULTS

Minimum size multiple pass Macroetch	Maximum size single pass Macroetch
1. _____ [36]	1. _____ [39]
2. _____ [37]	2. _____ [40]
3. _____ [38]	3. _____ [41]

ALL-WELD-METAL TENSION TEST RESULTS

Tensile strength, psi _____ [20]
 Yield point/strength, psi _____ [21]
 Elongation in 2 in, % _____ [22]
 Laboratory Test No: _____ [23]

Test Date _____ [42]
 Witnessed by _____ [43]

WELDING PROCEDURE

Pass No.	Electrode Size	Welding Current		Speed of Travel	Joint Detail
		Amperes	Volts		
[44]	[45]	[46]	[47]	[48]	[49]

We, the undersigned, certify that the statements in this record are correct.

Procedure No. _____ [50]
 Revision No. _____ [52]

Manufacturer or Contractor _____ [51]
 Authorized by _____ [53]
 Date _____ [54]

APPENDIX II-A

PERFORMANCE QUALIFICATION TEST RECORD (SMAW, GMAW, GTAW, FCAW, SAW, OFW, PAW)

Name _____ [1] Welder Welding Operator
 I.D. No. _____ [2] WPS Used _____ [3]
 Process(es) _____ [4] Transfer Mode (GMAW) _____ [5]
 Test Base Metal Specification _____ [6] to _____ [7]
 Material Number _____ [8] to _____ [9]
 Fuel Gas (OFW) _____ [10]
 AWS Filler Metal Classification(s) _____ [11] F No. _____ [12]
 Backing Yes No Double Side Single Side
 Current Polarity AC DCEP DCEN
 Consumable Insert Yes No Backing Gas Yes No

Test Joint Sketch

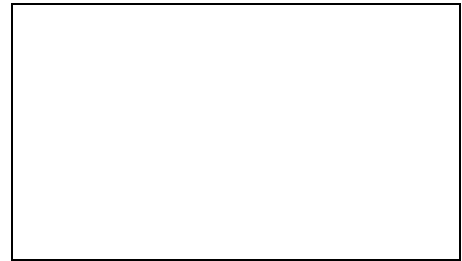

Test Weldment		Position Tested					Width (W)	Thickness (T)
Groove	Pipe	1G	2G	5G	6G		Thickness	Diameter
	Plate	1G	2G	3G		4G	Thickness	
Fillet	Pipe	1F	2F	2FR	4F	5F	Thickness	Diameter
	Plate	1F	2F	3F		4F	Thickness	
Cladding		1C	2C	3C	4C	5C	6C	Thickness
Hardfacing		1C	2C	3C	4C	5C	6C	Thickness

Progression Vertical Up Vertical Down

TEST RESULTS

Visual Test Pass Fail N/A
 Macro Test Pass Fail N/A
 Break Test Pass Fail N/A
 Bend Test Pass Fail N/A
 Radiographic Test Pass Fail N/A

REMARKS

 [13]

 [14]

 [15]

 [16]

 [17]

QUALIFICATION LIMITS

Process(es)

Weldment		Position					Deposited Thickness		
Groove	Pipe	F	H	V	O	All	t min.	t max.	Dia. min.
	Plate		H	V	O	All	t min.	t max.	
Cladding		F	H	V	O	All	t min.	t max.	
Hardfacing		F	H		O	All	t min.	t max.	
Weldment		Position					Base Metal Thickness		
Fillet	Pipe	F	H	V	O	All	T min.	T max.	Dia. min.
	Plate	F		V	O	All	T min.	T max.	

Progression Vertical Up Vertical Down

Base Metal M No(s) _____ [18]
 Filler Metal F No(s) _____ [20]
 Current Polarity AC DCEP DCEN
 Backing Gas _____ [21]

Fuel Gas (OFW) _____ [19]
 Backing Yes No
 Consumable Insert Yes No
 Transfer Mode (GMAW) _____ [22]

We, the undersigned, certify that the statements in this record are correct.

Date tested _____ [23]

Qualifier signature _____ [24]

Permission to reproduce granted by the American Welding Society.

APPENDIX II-B

Spectec, Inc.

905 Ridge Way, Eastern, Somewhere 84328, xxx-yyy-zzzz, FAX xxx-yyy-zzzz

WELDER PERFORMANCE QUALIFICATION RECORD

Welder's Name C. W. Practical ID No. 222-33-4444 Date 11-08-00
 WPS No. D1.1-3G-U-CJP-B-307
 Welding Process FCAW Type Manual
 Specification or Code AWS D1.1:2000, Structural Welding Code-Steel

Base Metal

Material Spec/Type/Grade A 36 To: Material Spec/Type/Grade A 36
 Thickness 1 in Thickness Range Qualified 1/8 in-Unlimited
 Base Metal Preparation Base metal shall be clean and free of moisture, oil, dirt, paint, coatings, rust, scale. etc. Cleaning shall leave no residue.

Joint Welded Single V-Groove with steel backing

Type of Weld Joint (See Figure 4.21, Test Plate for Unlimited Thickness)
 Bevel Angle 22.5° Root Face 0 Root Opening 1/4 in
 Backing Yes No Backing Type 1/4 x 1 in Steel Strap

Electrode

F No. 4 Specification A 5.18 Classification E71T-1 Size Range 1/16th

Filler Metal

F No. 4 Specification A 5.18 Classification E71T-1 Size Range 1/16th

Preheat

Preheat 50°F min. Interpass Temperature Max. 400°F

Position

Position 3G Progression Up

TEST RESULTS

Visual	Bends	Radiographic	Metallographic
Pass <input checked="" type="checkbox"/> Fail <input type="checkbox"/>	N/A <input type="checkbox"/> Pass <input checked="" type="checkbox"/> Fail <input type="checkbox"/>	N/A <input checked="" type="checkbox"/> Pass <input type="checkbox"/> Fail <input type="checkbox"/>	N/A <input checked="" type="checkbox"/> Pass <input type="checkbox"/> Fail <input type="checkbox"/>

Test conducted by _____ Laboratory test no. _____
 per _____ Test date _____

QUALIFIED FOR

Base Metal Group No.	Type Weld	Current	Backing	Penetration	Vertical
I(a) (Carbon and Low-Alloy Steel)	Single Side <input checked="" type="checkbox"/> Double Side <input type="checkbox"/>	AC <input type="checkbox"/> DCEN <input type="checkbox"/> DCEP <input checked="" type="checkbox"/>	With <input checked="" type="checkbox"/> Type <u>Steel</u> Open Root <input type="checkbox"/>	Complete <input checked="" type="checkbox"/> Partial <input type="checkbox"/>	Down <input type="checkbox"/> Up <input checked="" type="checkbox"/>

	Position				t, in		OD, in	
					Min.	Max.	Min.	Max.
Plate—Groove	1G <input checked="" type="checkbox"/>	2G <input checked="" type="checkbox"/>	3G <input checked="" type="checkbox"/>	4G <input type="checkbox"/>	1/8	Unlimited		
Pipe/Tube—Groove	1G <input checked="" type="checkbox"/>	2G <input checked="" type="checkbox"/>	5G <input type="checkbox"/>	6G <input type="checkbox"/>	1/8	Unlimited	Over 24	Unlimited
Plate—Fillet	1F <input checked="" type="checkbox"/>	2F <input checked="" type="checkbox"/>	3F <input checked="" type="checkbox"/>	4F <input type="checkbox"/>	1/8	Unlimited		
Pipe/Tube—Fillet	1F <input checked="" type="checkbox"/>	2F <input checked="" type="checkbox"/>	5F <input type="checkbox"/>	6F <input type="checkbox"/>	1/8	Unlimited		

The above individual is qualified to the above limits in accordance with AWS D1.1:2000, *Structural Welding Code—Steel*.

Qualified By John Smith Position Weld Supervisor Date 11-10-00
 (signature)

APPENDIX III

PREQUALIFIED COMPLETE JOINT PENETRATION GROOVE WELDED JOINTS

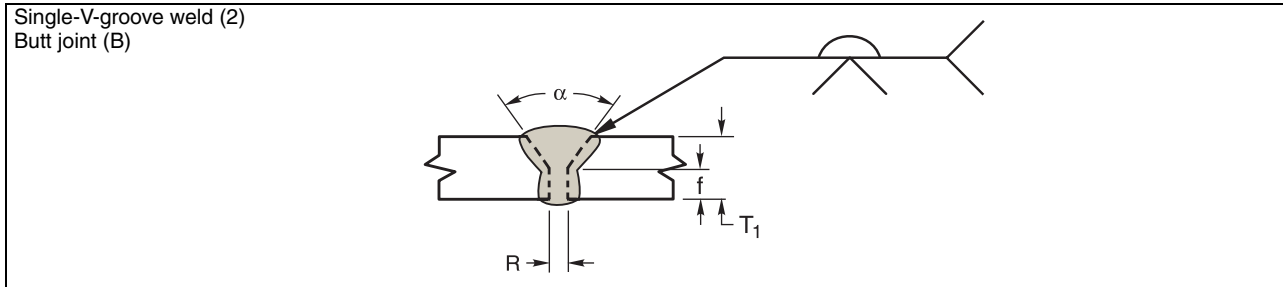

Welding Process	Joint Designation	Base Metal Thickness (U = unlimited)		Groove Preparation			Allowed Welding Positions	Gas Shielding for FCAW	Notes
		T ₁	T ₂	Root Opening Root Face Groove Angle	Tolerances				
					As Detailed	As Fitup			
SMAW	B-U2	U	—	R = 0 to 1/8 f = 0 to 1/8 $\alpha = 60^\circ$	+1/16, -0 +1/16, -0 +10°, -0°	+1/16, -1/8 Not limited +10°, -5°	All	—	b, c, d
GMAW FCAW	B-U2-GF	U	—	R = 0 to 1/8 f = 0 to 1/8 $\alpha = 60^\circ$	+1/16, -0 +1/16, -0 +10°, -0°	+1/16, -1/8 Not limited +10°, -5°	All	Not required	a, b, d
SAW	B-L2c-S	Over 1/2 to 1	—	R = 0 f = 1/4 max. $\alpha = 60^\circ$	R = ±0 f = +0, -f $\alpha = +10^\circ, -0^\circ$	+1/16, -0 ±1/16 +10°, -5°	F	—	b, d
		Over 1 to 1-1/2	—	R = 0 f = 1/2 max. $\alpha = 60^\circ$					
		Over 1-1/2 to 2	—	R = 0 f = 5/8 max. $\alpha = 60^\circ$					

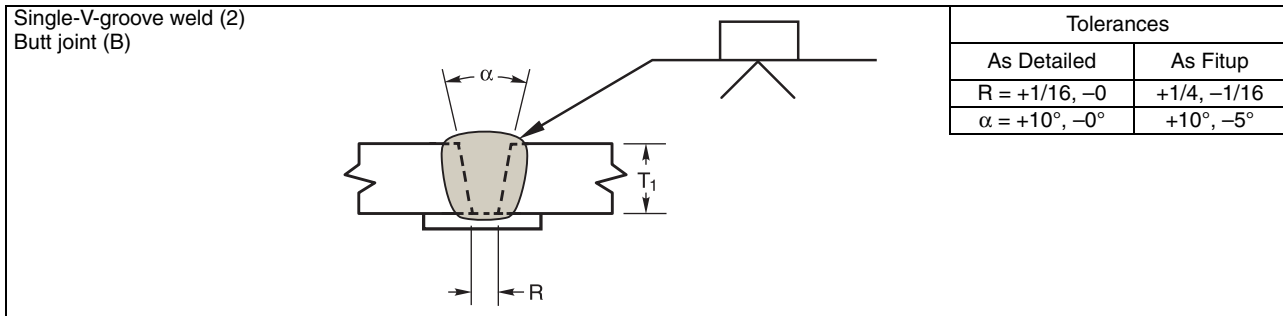

Tolerances	
As Detailed	As Fitup
R = +1/16, -0	+1/4, -1/16
$\alpha = +10^\circ, -0^\circ$	+10°, -5°

Welding Process	Joint Designation	Base Metal Thickness (U = unlimited)		Groove Preparation		Allowed Welding Positions	Gas Shielding for FCAW	Notes
		T ₁	T ₂	Root Opening	Groove Angle			
SMAW	B-U2a	U	—	R = 1/4	$\alpha = 45^\circ$	All	—	c, d
				R = 3/8	$\alpha = 30^\circ$	F, V, OH	—	c, d
				R = 1/2	$\alpha = 20^\circ$	F, V, OH	—	c, d
GMAW FCAW	B-U2a-GF	U	—	R = 3/16	$\alpha = 30^\circ$	F, V, OH	Required	a, d
				R = 3/8	$\alpha = 30^\circ$	F, V, OH	Not req.	a, d
				R = 1/4	$\alpha = 45^\circ$	F, V, OH	Not req.	a, d
SAW	B-L2a-S	2 max.	—	R = 1/4	$\alpha = 30^\circ$	F	—	d
SAW	B-U2-S	U	—	R = 5/8	$\alpha = 20^\circ$	F	—	d

^a Not prequalified for GMAW-S nor GTAW.

^b Backgouge root to sound metal before welding second side.

^c SMAW detailed joints may be used for prequalified GMAW (except GMAW-S) and FCAW.

^d The orientation of the two members in the joints may vary from 135° to 180° for butt joints, or 45° to 135° for corner joints, or 45° to 90° for T-joints.

APPENDIX IV

PIPE SCHEDULES

Pipe Size	O.D. (in)	5s	5	10s	10	20	30	40s Std.	40	60	80s & E.H.	80	100	120	140	160	Dble. E.H.	
1/8	0.405		0.035 0.1383	0.049 0.1863	0.049 0.1863			0.068 0.2447	0.068 0.2447		0.095 0.3145	0.095 0.3145						
1/4	0.540		0.049 0.2570	0.065 0.3297	0.065 0.3297			0.088 0.4248	0.088 0.4248		0.119 0.5351	0.119 0.5351						
3/8	0.675		0.049 0.3276	0.065 0.4235	0.065 0.4235			0.091 0.5676	0.091 0.5676		0.126 0.7388	0.126 0.7388						
1/2	0.840	0.065 0.5383	0.065 0.5383	0.083 0.6710	0.083 0.6710			0.109 0.8510	0.109 0.8510		0.147 1.088	0.147 1.088					0.188 1.304	0.294 1.714
3/4	1.050	0.065 0.6838	0.065 0.6838	0.083 0.8572	0.083 0.8572			0.113 1.131	0.113 1.131		0.154 1.474	0.154 1.474					0.219 1.937	0.308 2.441
1	1.315	0.065 0.8678	0.065 0.8678	0.109 1.404	0.109 1.404			0.133 1.679	0.133 1.679		0.179 2.172	0.179 2.172					0.250 2.844	0.358 3.659
1-1/4	1.660	0.065 1.107	0.065 1.107	0.109 1.806	0.109 1.806			0.140 2.273	0.140 2.273		0.191 2.997	0.191 2.997					0.250 3.765	0.382 5.214
1-1/2	1.900	0.065 1.274	0.065 1.274	0.109 2.085	0.109 2.085			0.145 2.718	0.145 2.718		0.200 3.631	0.200 3.631					0.281 4.859	0.400 6.408
2	2.375	0.065 1.604	0.065 1.604	0.109 2.638	0.109 2.638			0.154 3.653	0.154 3.653		0.218 5.022	0.218 5.022					0.344 7.444	0.436 9.029
2-1/2	2.875	0.083 2.475	0.083 2.475	0.120 3.531	0.120 3.531			0.203 5.793	0.203 5.793		0.276 7.661	0.276 7.661					0.375 10.01	0.552 13.70
3	3.500	0.083 3.029	0.083 3.029	0.120 4.332	0.120 4.332			0.216 7.576	0.216 7.576		0.300 10.25	0.300 10.25					0.438 14.32	0.600 18.58
3-1/2	4.000	0.083 3.472	0.083 3.472	0.120 4.973	0.120 4.973			0.226 9.109	0.226 9.109		0.318 12.51	0.318 12.51						0.636 22.85
4	4.500	0.083 3.915	0.083 3.915	0.120 5.613	0.120 5.613			0.237 10.79	0.237 10.79	0.281 12.66	0.337 14.98	0.337 14.98		0.438 19.01			0.531 22.51	0.674 27.54
4-1/2	5.000							0.247 12.53			0.355 17.61							0.710 32.53
5	5.563	0.109 6.349	0.109 6.349	0.134 7.770	0.134 7.770			0.238 14.62	0.258 14.62		0.375 20.78	0.375 20.78		0.500 27.04			0.625 32.96	0.750 38.55
6	6.625	0.109 7.585	0.109 7.585	0.134 9.290	0.134 9.289			0.280 18.97	0.280 18.97		0.432 28.57	0.432 28.57		0.562 36.39			0.719 45.30	0.864 43.16
7	7.625							0.301 23.57			0.500 38.05							0.875 63.08
8	8.625	0.109 9.914	0.109 9.914	0.148 13.40	0.148 13.40	0.250 22.36	0.277 24.70	0.322 28.55	0.322 28.55	0.406 35.64	0.500 43.39	0.500 43.39	0.594 50.87	0.719 60.93	0.812 67.76	0.906 74.69	0.875 72.42	
9	9.625							0.342 33.90			0.500 48.72							
10	10.750	0.134 15.19	0.134 15.19	0.165 18.65	0.165 18.70	0.250 28.04	0.307 34.24	0.365 40.48	0.365 40.48	0.500 54.74	0.500 54.74	0.594 64.33	0.719 76.93	0.844 89.20	1.000 104.1	1.125 115.7		
11	11.750							0.375 45.55			0.500 60.07							
12	12.750	0.156 21.07	0.165 22.18	0.180 24.16	0.180 24.20	0.250 33.38	0.330 43.77	0.375 49.56	0.406 53.33	0.562 73.16	0.500 65.42	0.688 88.51	0.844 107.2	1.000 125.5	1.125 139.7	1.312 160.3		
14	14.000	0.156 23.07		0.188 27.73	0.250 36.71	0.312 45.68	0.375 54.57	0.375 54.57	0.438 63.37	0.594 84.91	0.500 72.09	0.750 106.1	0.938 130.7	1.094 150.7	1.250 170.2	1.406 189.1		
16	16.000	0.165 27.90		0.188 31.75	0.250 42.05	0.312 52.36	0.375 62.58	0.375 62.58	0.500 82.77	0.656 107.5	0.500 82.77	0.844 136.5	1.031 164.8	0.129 192.3	1.438 223.5	1.594 245.1		
18	18.000	0.165 31.43		0.188 35.76	0.250 47.39	0.312 59.03	0.438 82.06	0.375 70.59	0.562 104.8	0.750 138.2	0.500 93.45	0.938 170.8	1.156 208.0	1.375 244.1	1.562 274.2	1.781 308.5		
20	20.000	0.188 39.78		0.218 46.05	0.250 52.73	0.375 78.60	0.500 104.1	0.375 78.60	0.594 122.9	0.812 166.4	0.500 104.1	1.031 208.9	1.281 256.1	1.500 296.4	1.750 341.1	1.969 379.0		
24	24.000	0.218 55.37		0.250 63.41	0.250 63.41	0.375 94.62	0.562 140.8	0.375 94.62	0.688 171.2	0.969 238.1	0.500 125.5	1.219 296.4	1.531 367.4	1.812 429.4	2.062 483.1	2.343 541.9		

UPPER FIGURES
Wall Thickness
in inches

DIMENSIONS AND WEIGHTS OF SEAMLESS AND WELDED STEEL PIPE

LOWER FIGURES
Weight per foot
in pounds

APPENDIX V

ACCEPTABLE AND UNACCEPTABLE WELD PROFILES

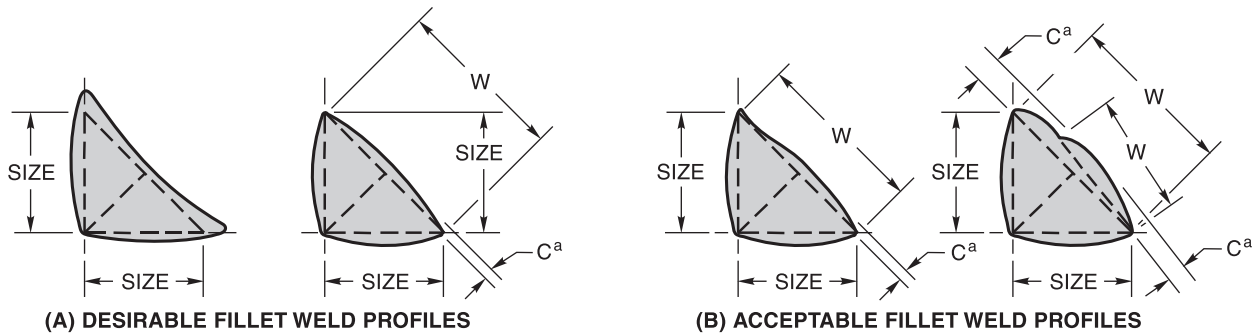

^aConvexity, C, of a weld or individual surface bead with dimension W shall not exceed the value of the following table:

WIDTH OF WELD FACE OR INDIVIDUAL SURFACE BEAD, W	MAX. CONVEXITY, C
$W \leq 5/16$ in	1/16 in
$W > 5/16$ in TO $W < 1$ in	1/8 in
$W \geq 1$ in	3/16 in

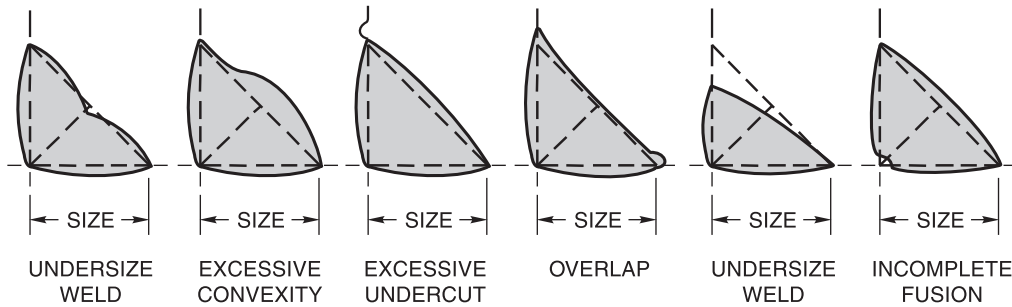

(C) UNACCEPTABLE FILLET WELD PROFILES

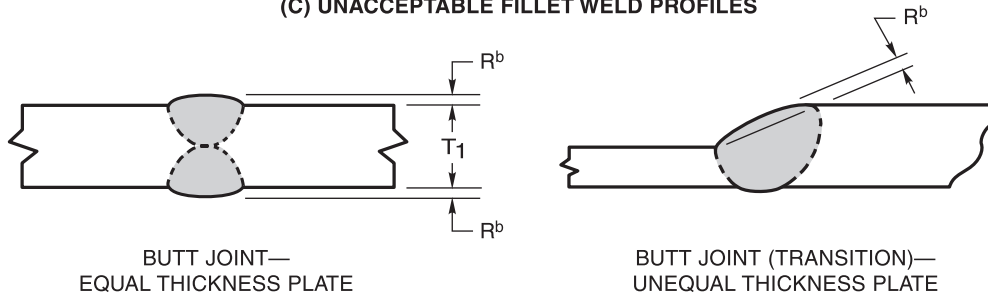

^bReinforcement R shall not exceed 1/8 in.

(D) ACCEPTABLE GROOVE WELD PROFILE IN BUTT JOINT

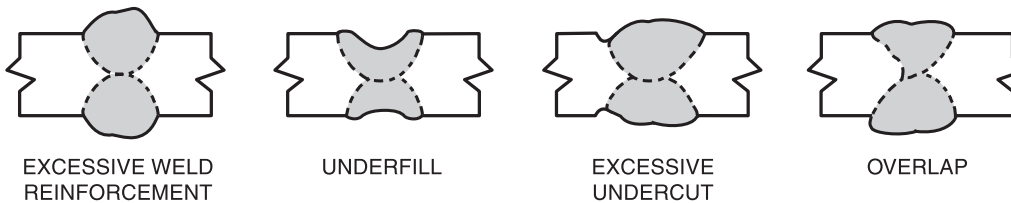

(E) UNACCEPTABLE GROOVE WELD PROFILES IN BUTT JOINTS

APPENDIX VI

WELD PROFILE ACCEPTANCE DESCRIPTION

- (1) The faces of fillet welds may be slightly convex, flat, or slightly concave as shown in Appendix V (A) and (B), with none of the unacceptable profiles shown in (C). Except at outside corner joints, the convexity, C, of a weld or individual surface bead with dimension W shall not exceed the values noted in the table in Appendix V.
- (2) Groove welds shall preferably be made with slight or minimum reinforcement except as may be otherwise provided. In the case of butt and corner joints, the reinforcement shall not exceed 1/8 in [3.2 mm] in height and shall have gradual transition to the plane of the base metal surface. See Appendix V. They shall be free of the discontinuities shown for butt joints in (E).
- (3) Surfaces of groove welds required to be flush shall be finished so as not to reduce the thickness of the thinner base metal or weld metal by more than 1/32 in [0.8 mm] or 5% of the thickness, whichever is smaller, nor leave reinforcement that exceeds 1/32 in [0.8 mm]. However, all reinforcement must be removed where the weld forms part of a faying or contact surface. Any reinforcement must blend smoothly into the plate surfaces with transition areas free from weld undercut. Chipping may be used provided it is followed by grinding. Where surface finishing is required, its roughness value shall not exceed 250 μin [6.3 μm]. Surfaces finished to values of over 125 μin [3.2 μm] through 250 μin [6.3 μm] shall be finished so that the grinding marks are parallel to the direction of primary stress. Surfaces finished to values of 125 μin [3.2 μm] or less may be finished in any direction.
- (4) Ends of groove welds required to be flush shall be finished so as not to reduce the width beyond the detailed width or the actual width furnished, whichever is greater, by more than 1/8 in [3.2 mm] or so as not to leave reinforcement at each end that exceeds 1/8 in [3.2 mm]. Ends of welds in butt joints shall be faired to adjacent plate or shape edges at a slope not to exceed 1 in 10.
- (5) Welds shall be free from overlap.

APPENDIX VII

VISUAL WELD INSPECTION ACCEPTANCE CRITERIA

Slag shall be removed from all completed welds. All welds and the adjacent base metal shall be cleaned by brushing or by any other suitable means prior to visual inspection. All welds shall meet the following visual acceptance criteria prior to any nondestructive or destructive testing. To be visually acceptable, a weld shall meet the following criteria:

- (1) The weld shall have no cracks.
- (2) Thorough fusion shall exist between adjacent layers of weld metal and between weld metal and base metal.
- (3) All craters shall be filled to the full cross section of the weld.
- (4) Weld profiles shall be in accordance with Appendices V and VI.
- (5) When the weld is transverse to the primary tensile stress in the part that is undercut, the undercut shall be no more than 0.010 in [0.25 mm] deep.
- (6) When the weld is parallel to the primary tensile stress in the part that is undercut, the undercut shall be no more than 1/32 in [0.80 mm] deep.
- (7) The sum of the diameters of visible porosity shall not exceed 3/8 in [9.5 mm] in any linear inch of weld nor shall the sum exceed 3/4 in [19.0 mm] in any 12 in [305 mm] length of weld.
- (8) Any single continuous fillet weld shall be permitted to underrun the nominal fillet weld size specified by 1/16 in [1.6 mm].
- (9) Visual inspections of welds in all steels may begin immediately after the completed welds have cooled to ambient temperature. Final visual inspection for ASTM A 514 and A 517 steel welds shall be performed not less than 48 hours after completion of the weld and removal of preheat.
- (10) Arc strikes outside the weld groove or area are prohibited.

APPENDIX VIII

TEST RESULTS REQUIRED, GUIDED BENDS

All Guided Bend Tests. The convex surface of the bend test specimen shall be visually examined for surface discontinuities. For acceptance, the surface shall meet the following criteria:

- (1) No single discontinuity shall exceed $1/8$ in [3.2 mm] measured in any direction.
- (2) The sum of the greatest dimensions of all discontinuities exceeding $1/32$ in [0.8 mm] but less than or equal to $1/8$ in [3.2 mm] shall not exceed $3/8$ in [9.5 mm].
- (3) Corner cracks shall not exceed $1/4$ in [6.4 mm] unless the crack results from a visible slag inclusion or other fusion type discontinuity, then the $1/8$ in [3.2 mm] maximum shall apply.

The specimens with corner cracks exceeding $1/4$ in [6.4 mm] with no evidence of slag inclusions or other fusion type discontinuities shall be disregarded, and a replacement test specimen from the original weldment shall be tested.

APPENDIX IX

WELD METAL ANALYSIS

A-NUMBERS Classification of Ferrous Weld Metal Analysis for Procedure Qualification

A-No.	Types of Weld Deposit	Analysis, % ^a					
		C	Cr	Mo	Ni	Mn	Si
1	Mild Steel	0.15	—	—	—	1.60	1.00
2	Carbon–Molybdenum	0.15	0.50	0.40–0.65	—	1.60	1.00
3	Chrome (0.4% to 2%)–Molybdenum	0.15	0.40–2.00	0.40–0.65	—	1.60	1.00
4	Chrome (2% to 6%)–Molybdenum	0.15	2.00–6.00	0.40–1.50	—	1.60	2.00
5	Chrome (6% to 10.5%)–Molybdenum	0.15	6.00–10.50	0.40–1.50	—	1.20	2.00
6	Chrome–Martensitic	0.15	11.00–15.00	0.70	—	2.00	1.00
7	Chrome–Ferritic	0.15	11.00–30.00	1.00	—	1.00	3.00
8	Chromium–Nickel	0.15	14.50–30.00	4.00	7.50–15.00	2.50	1.00
9	Chromium–Nickel	0.30	25.00–30.00	4.00	15.00–37.00	2.50	1.00
10	Nickel to 4%	0.15	—	0.55	0.80–4.00	1.70	1.00
11	Manganese–Molybdenum	0.17	—	0.25–0.75	0.85	1.25–2.25	1.00
12	Nickel–Chrome–Molybdenum	0.15	1.50	0.25–0.80	1.25–2.80	0.75–2.25	1.00

^aSingle values shown above are maximum.

APPENDIX X

ELECTRODE GROUPS

F-NUMBERS

Grouping of Electrodes and Welding Rods for Qualification

F-No.	AWS Specification	AWS Classification
Steel		
1	A5.1	EXX20, EXX22, EXX24, EXX27, EXX28
1	A5.4	EXXX(X)-25, EXXX(X)-26
1	A5.5	EXX20-XX, EXX27-XX
2	A5.1	EXX12, EXX13, EXX14, EXX19
2	A5.5	E(X)XX13-XX
3	A5.1	EXX10, EXX11
3	A5.5	E(X)XX10-XX, E(X)XX11-XX
4	A5.1	EXX15, EXX16, EXX18, EXX18M, EXX48
4	A5.4 other than austenitic and duplex	EXXX(X)-15, EXXX(X)-16, EXXX(X)-17
4	A5.5	E(X)XX15-XX, E(X)XX16-XX, E(X)XX18-XX, E(X)XX18M, E(X)XX18M1
5	A5.4 austenitic and duplex	EXXX(X)-15, EXXX(X)-16, EXXX(X)-17
6	A5.2	RX
6	A5.9	ERXXX(XXX), ECXXX(XXX), EQXXX(XXX)
6	A5.17	FXXX-EXX, FXXX-ECX
6	A5.18	ERXXS-X, EXXC-X, EXXC-XX
6	A5.20	EXXT-X, EXXT-XM
6	A5.22	EXXTX-X, RXXXT1-5
6	A5.23	FXXX-EXXX-X, FXXX-ECXXX-X
6	A5.23	FXXX-EXXX-XN, FXXX-ECXXX-XN
6	A5.25	FESXX-EXXX, FESXX-EWXX
6	A5.26	EGXXS-X, EGXXT-X
6	A5.28	ERXXS-XXX, EXXC-XXX
6	A5.29	EXXTX-X
6	A5.30	INXXX
Aluminum and Aluminum Alloys		
21	A5.3	E1100, E3003
21	A5.10	ER1100, R1100, ER1188, R1188
22	A5.10	ER5183, R5183, ER5356, R5356, ER5554, R5554, ER5556, R5556, ER5654, R5654
23	A5.3	E4043
23	A5.10	ER4009, R4009, ER4010, R4011, R4010, ER4043, R4043, ER4047, R4047, ER4145, R4145, ER4643, R4643
24	A5.10	R206.0, R-C355.0, R-A356.0, R357.0, R-A357.0
25	A5.10	ER2319, R2319

APPENDIX X (Continued)

ELECTRODE GROUPS

F-NUMBERS

Grouping of Electrodes and Welding Rods for Qualification

F-No.	AWS Specification	AWS Classification
Copper and Copper Alloys		
31	A5.6 and A5.7	RCu, ECu
32	A5.6	ECuSi and ERCuSi-A
33	A5.6 and A5.7	ECuSn-A, ECuSn-C, ERCuSn-A
34	A5.6, A5.7, and A5.30	ECuNi, ERCuNi, IN67
35	A5.8	RBCuZn-A, RBCuZn-B, RCuZn-C, RBCuZn-D
36	A5.6 and A5.7	ERCuAl-A1, ERCuAl-A2, ERCuAl-A3, ECuAl-A2, ECuAl-B
37	A5.6 and A5.7	RCuNiAl, ECuMnNiAl, ERCuNiAl, ERCuMnNiAl
Nickel and Nickel Alloys		
41	A5.11, A5.14, and A5.30	ENi-1, ERNi-1, IN61
42	A5.11, A5.14, and A5.30	ENiCu-7, ERNiCu-7, ERNiCu-8, IN60
43	A5.11	ENiCrFe-1, 2, 3, 4, 7, 9, and 10; ENiCrMo-2, 3, 6, and 12; ENiCrCoMo-1
43	A5.14	ERNiCr-3, 4, and 6; ERNiCrFe-5, 6, 7, 8, and 11; ERNiCrCoMo-1; ERNiCrMo-2 and 3
43	A5.30	IN6A, IN62, IN82
44	A5.11	ENiMo-1, 3, 7, 8, 9, and 10; ENiCrMo-4, 5, 7, 10, 13, and 14
44	A5.14	ERNiMo-1, 2, 3, 7 (B2), 8, 9, and 10; ERNiCrMo-4, 7 (alloy C4), 10, 13, 14; ERNiCrWMo-1
45	A5.11	ENiCrMo-1, 9, and 11
45	A5.14	ERNiCrMo-1, 8, 9, and 11; ERNiFeCr-1
Titanium and Titanium Alloys		
51	A5.16	ERTi-1, ERTi-2, ERTi-3, ERTi-4
52	A5.16	ERTi-7
53	A5.16	ERTi-9, ERTi-9ELI
54	A5.16	ERTi-12
55	A5.16	ERTi-5, ERTi-5ELI, ERTi-6, ERTi-6ELI, ERTi-15
Zirconium and Zirconium Alloys		
61	A5.24	ERZr2, ERZr3, ERZr4
Hardfacing Weld Metal Overlay		
71	A5.13 and A5.21	RXXX-X, EXXX-X
Magnesium Alloys		
91	A5.19	ER AZ61A, ER AZ92A, ER EZ33A, ER AZ101A, R AZ61A, R AZ92A, R AZ101A, R EZ33A

APPENDIX XI

WELDER QUALIFICATION TEST REQUIREMENTS

1. Tests on plate									
Type of Weld	Thickness of Test Plate (T) As Welded, in	Visual Inspection	Number of Specimens				T-Joint Break	Macroetch Test	Plate Thickness Qualified, in
			Bend Tests						
			Face	Root	Side				
Groove	3/8	Yes	1	1	—	—	—	3/4 max. ^a	
Groove	3/8 < T < 1	Yes	—	—	2	—	—	1/8–2T ^a	
Groove	1 or over	Yes	—	—	2	—	—	Unlimited ^a	
Fillet Option No. 1	1/2	Yes	—	—	—	1	1	Unlimited	
Fillet Option No. 2	3/8	Yes	—	2	—	—	—	Unlimited	

^aAlso qualifies for welding fillet welds on material of unlimited thickness.

2. Tests on pipe or tubing												
Type of Weld	Pipe or Tubing Size, As Welded		Visual Inspection	Number of Specimens						Pipe or Tube Size Qualified, in	Plate, Pipe, or Tube Wall Thickness Qualified, in	
	Diam	Nominal Thickness		All Positions Except 5G and 6G			5G and 6G Positions Only				Min.	Max. ^a
				Face Bend	Root Bend	Side Bend	Face Bend	Root Bend	Side Bend			
Groove	2 in or 3 in	Sch. 80 Sch. 40	Yes	1	1	—	2	2	—	4 or smaller	1/8	3/4 ^a
Groove	6 in or 8 in	Sch. 120 Sch. 80	Yes	—	—	2	—	—	4	4 or larger	3/16	Unlimited ^a

^aAlso qualifies for welding fillet welds on material of unlimited thickness.

APPENDIX XI (Continued)

Welder Qualification—Type and Position Limitations

Qualification Test		Type of Weld and Position of Welding Qualified			
		Plate		Pipe	
Weld	Plate or Pipe Positions	Groove	Fillet	Groove	Fillet
Plate-Groove	1G 2G 3G 4G 3G and 4G	F F, H F, H, V F, OH All	F, H F, H F, H, V F, H, OH All	F ^a F, H ^a F, H, V ^a	F, H F, H F, H F F, H
Plate-Fillet ^b	1F 2F 3F 4F 3F and 4F		F F, H F, H, V F, H, OH All		F F, H F, H, V F, H, OH All
Pipe-Groove	1G 2G 5G 6G 2G and 5G 6GR	F F, H F, V, OH Note c Note c All	F, H F, H F, V, OH Note c Note c All	F F, H F, V, OH Note c Note c All	F, H F, H F, V, OH Note c Note c All
Pipe-Fillet	1F 2F 2F Rolled 4F 4F and 5F		F F, H F, H F, H, OH All		F F, H F, H F, H, OH All

^aWelders qualified to weld tubulars over 24 in [600 mm] in diameter with backing or backgouging, for the test position indicated.

^bNot applicable for fillet welds between parts having a dihedral angle (ψ) of 60° or less.

^cQualified for all except groove welds for T-, Y-, and K-connections.

APPENDIX XII

FILLET PROCEDURE QUALIFICATION REQUIREMENTS

Test Specimen	Fillet Size	Number of Welds per Procedure	Test Specimens Required			Sizes Qualified	
			Macroetch	All-Weld-Metal Tension	Side-Bend	Plate Thickness	Fillet Size
Plate T-test	Single-pass, max. size to be used in construction	1 in each position to be used	3 faces	—	—	Unlimited	Max. tested single-pass and smaller
	Multiple-pass, min. size to be used in construction	1 in each position to be used	3 faces	—	—	Unlimited	Min. tested multiple-pass and larger

APPENDIX XIII

GROOVE PROCEDURE QUALIFICATION REQUIREMENTS

1. Tests on plate							
Plate Thickness (T) Tested, in	Number of Sample Welds per Position	NDT ^a	Test Specimens Required				Nominal Plate Thickness Qualified, T in ^b
			Reduced-Section Tension	Root-Bend	Face-Bend	Side-Bend	
$1/8 \leq T < 3/8$	1	Yes	2	2	2	—	1/8 to 2T
3/8	1	Yes	2	2	2	—	1/8 to 3/4
$3/8 < T < 1$	1	Yes	2	—	—	4	1/8 to 2T
1 and over	1	Yes	2	—	—	4	Unlimited

^aA minimum of 6 in of effective weld length shall be tested by radiographic or ultrasonic testing prior to mechanical testing.

^bFor square groove welds, the maximum thickness qualified shall be limited to thickness tested.

Note: All welded test plates shall be visually inspected.

2. Tests on pipe or tubing										
Pipe Size of Sample Weld		Number of Sample Welds per Position	NDT ^a	Test Specimens Required				Diameter Qualified, in	Thickness Qualified, in	
				Reduced-Section Tension	Root-Bend	Face-Bend	Side-Bend		Min.	Max.
Diam.	Wall Thickness, T									
2 in or 3 in	Sch. 80 Sch. 40	2	Yes	2	2	2	—	3/4 through 4	1/8	3/4
6 in or 8 in	Sch. 120 Sch. 80	1	Yes	2	—	—	4	4 and over	3/16	Unlimited
Job Size Pipe or Tubing										
Diam.	Wall Thickness, T									
< 24 in	$1/8 \leq T \leq 3/8$ in	1	Yes	2	2	2	—	Test diam. and over	1/8	2T
	$3/8 < T < 3/4$ in	1	Yes	2	—	—	4		T/2	2T
	$T \geq 3/4$ in	1	Yes	2	—	—	4		3/8	Unlimited
≥ 24 in	$1/8 \leq T \leq 3/8$ in	1	Yes	2	2	2	—	Test diam. and over 24 and over 24 and over	1/8	2T
	$3/8 < T < 3/4$ in	1	Yes	2	—	—	4		T/2	2T
	$T \geq 3/4$ in	1	Yes	2	—	—	4		3/8	Unlimited

^aFor pipe or tubing, the full circumference of the completed weld shall be tested by RT or UT prior to mechanical testing.

Note: All welded test pipes shall be visually inspected.

APPENDIX XIV

PREQUALIFIED BASE METAL—FILLER METAL COMBINATIONS FOR MATCHING STRENGTH

G r o u p	Steel Specification Requirements					Filler Metal Requirements				
	Steel Specification ^{a,b}	Minimum Yield Point/Strength		Tensile Range		Process	AWS Electrode Specification ^c	Electrode Classification ^g		
		ksi	MPa	ksi	MPa					
I	ASTM A 36 ^d		36	250	58–80	400–550	SMAW	A5.1 E60XX, E70XX		
	ASTM A 53	A5.5	35	240	60 min.	415 min.				
	ASTM A 106	Grade B	35	240	60 min.	415 min.				
	ASTM A 131	Grades A, B, CS, D, DS, E	34	235	58–71	400–490	SAW	A5.17 A5.23 ^f	E70XX-X F6XX-EXXX, F6XX-ECXXX, F7XX-EXXX, F7XX-ECXXX F7XX-EXXX-XX, F7XX-ECXXX-XX	
	ASTM A 139	Grade B	35	241	60 min.	414 min.				
	ASTM A 381	Grade Y35	35	240	60 min.	415 min.				
	ASTM A 500	Grade A	33	228	45 min.	310 min.				
		Grade B	42	290	58 min.	400 min.				
	ASTM A 501		36	250	58 min.	400 min.	GMAW	A5.18 A5.28 ^f	ER70S-X, E70C-XC, E70C-XM (Electrodes with the -GS suffix are excluded) ER70S-XXX, E70C-XXX	
	ASTM A 516	Grade 55	30	205	55–75	380–515				
		Grade 60	32	220	60–80	415–550				
	ASTM A 524	Grade I	35	240	60–85	415–586				
		Grade II	30	205	55–80	380–550				
		ASTM A 529		42	290	60–85	415–585	FCAW	A5.20 A5.29 ^f	E6XT-X, E6XT-XM, E7XT-X, E7XT-XM (Electrodes with the -2, -2M, -3, -10, -13, -14X, and -GS suffix are excluded) E6XTX-X, E6XT-XM, E7XTX-X, E7XTX-XM
		ASTM A 570	Grade 30	30	205	49 min.	340 min.			
			Grade 33	33	230	52 min.	360 min.			
			Grade 36	36	250	53 min.	365 min.			
			Grade 40	40	275	55 min.	380 min.			
			Grade 45	45	310	60 min.	415 min.			
		ASTM A 573	Grade 65	35	240	65–77	450–530			
		Grade 58	32	220	58–71	400–490				
	ASTM A 709	Grade 36 ^d	36	250	58–80	400–550				
	API 5LX	Grade B	35	240	60	415				
		Grade X42	42	290	60	415				
	ABS	Grades A, B, D, CS, DS			58–71	400–490				
		Grade E ^e			58–71	400–490				

Note: ASTM A 570 Grade 50 has been deleted from Group I and added to Group II.

(Continued)

APPENDIX XIV (Continued)

G r o u p	Steel Specification Requirements					Filler Metal Requirements				
	Steel Specification ^{a, b}	Minimum Yield Point/Strength		Tensile Range		Process	AWS Electrode Specification ^c	Electrode Classification ^g		
		ksi	MPa	ksi	MPa					
II	ASTM A 131	Grades AH32, DH32, EH32	46	315	68–85	470–585	SMAW	A5.1	E7015, E7016, E7018, E7028	
		Grades AH36, DH36, EH36	51	350	71–90	490–620		A5.5 ^f	E7015-X, E7016-X, E7018-X	
	ASTM A 441		40–50	275–345	60–70	415–485				
	ASTM A 516	Grade 65		35	240	65–85	450–585	SAW	A5.17	F7XX-EXXXX, F7XX-ECXXX
		Grade 70		38	260	70–90	485–620		A5.23 ^f	F7XX-EXXXX-XX, F7XX-ECXXX-XX
	ASTM A 537	Class 1		45–50	310–345	65–90	450–620	GMAW	A5.18	ER70S-X, E70C-XC, E70C-XM (Electrodes with the -GS suffix are excluded)
	ASTM A 570	Grade 50		50	345	65	450		A5.28 ^f	ER70S-XXX, E70C-XXX
		Grade 55		55	380	70	480			
	ASTM A 572	Grade 42		42	290	60 min.	415 min.	FCAW	A5.20	E7XT-X, E7XT-XM (Electrodes with the -2, -2M, -3, -10, -13, -14, and -GS suffix are excluded)
	ASTM A 572	Grade 50		50	345	65 min.	450 min.		A5.29 ^f	E7XTX-X, E7XTX-XM
	ASTM A 588 ^e	(4 in [100 mm] and under)		50	345	70 min.	485 min.			
	ASTM A 595	Grade A		55	380	65 min.	450 min.			
		Grades B and C		60	415	70 min.	480 min.			
	ASTM A 606 ^e			45–50	310–340	65 min.	450 min.			
	ASTM A 607	Grade 45		45	310	60 min.	410 min.			
		Grade 50		50	345	65 min.	450 min.			
		Grade 55		55	380	70 min.	480 min.			
	ASTM A 618	Grades Ib, II, III		46–50	315–345	65 min.	450 min.			
	ASTM A 633	Grade A		42	290	63–83	430–570			
		Grades C, D		50	345	70–90	485–620			
		(2-1/2 in [65 mm] and under)								
	ASTM A 709	Grade 50		50	345	65 min.	450 min.			
		Grade 50W		50	345	70 min.	485 min.			
	ASTM A 710	Grade A, Class 2 > 2 in [50 mm]		55	380	65 min.	450 min.			
	ASTM A 808	(2-1/2 in [65 mm] and under)		42	290	60 min.	415 min.			
	ASTM A 913	Grade 50		50	345	65 min.	450 min.			
	ASTM A 992			50–65	345–450	65	450			
	API 2H	Grade 42		42	290	62–80	430–550			
		Grade 50		50	345	70 min.	485 min.			
	API 2W	Grade 42		42–67	290–462	62 min.	427 min.			
	Grade 50		50–75	345–517	65 min.	448 min.				
	Grade 50T		50–80	345–552	70 min.	483 min.				
API 2Y	Grade 42		42–67	290–462	62 min.	427 min.				
	Grade 50		50–75	345–517	65 min.	448 min.				
	Grade 50T		50–80	345–552	70 min.	483 min.				
API 5LX	Grade X52		52	360	66–72	455–495				
ABS	Grades AH32, DH32, EH32		45.5	315	71–90	490–620				
	Grades AH36, DH36, EH36 ^e		51	350	71–90	490–620				

(Continued)

APPENDIX XIV (Continued)

G r o u p	Steel Specification Requirements						Filler Metal Requirements		
	Steel Specification ^{a, b}		Minimum Yield Point/Strength		Tensile Range		Process	AWS Electrode Specification ^c	Electrode Classification ^g
			ksi	MPa	ksi	MPa			
III	API 2W	Grade 60	60–90	414–621	75 min.	517 min.	SMAW	A5.5 ^f	E8015-X, E8016-X, E8018-X
	API 2Y	Grade 60	60–90	414–621	75 min.	517 min.	SAW	A5.23 ^f	F8XX-EXXX-XX, F8XX-ECXXX-XX
	ASTM A 572	Grade 60	60	415	75 min.	515 min.			
		Grade 65	65	450	80 min.	550 min.	GMAW	A5.28 ^f	ER80S-XXX, E80C-XXX
	ASTM A 537	Class 2 ^e	46–60	315–415	80–100	550–690			
	ASTM A 633	Grade E ^e	55–60	380–415	75–100	515–690	FCAW	A5.29 ^f	E8XTX-X, E8XTX-XM
	ASTM A 710	Grade A, Class 2 ≤ 2 in [50 mm]	60–65	415–450	72 min.	495 min.			
	ASTM A 710	Grade A, Class 3 > 2 in [50 mm]	60–65	415–450	70 min.	485 min.			
ASTM A 913 ^h	Grade 60	60	415	75 min.	520 min.				
	Grade 65	65	450	80 min.	550 min.	SMAW	A5.5 ^f	E9015-X, E9016-X, E9018-X, E9018-M	
IV	ASTM A 709	Grade 70W	70	485	90–110	620–760	SAW	A5.23 ^f	F9XX-EXXX-XX, F9XX-ECXXX-XX
	ASTM A 852		70	485	90–110	620–760	GMAW	A5.28 ^f	ER90S-XXX, E90C-XXX
						FCAW	A5.29 ^f	E9XTX-X, E9XTX-XM	

^a In joints involving base metals of different groups, either of the following filler metals may be used: (1) that which matches the higher strength base metal, or (2) that which matches the lower strength base metal and produces a low-hydrogen deposit. Preheating shall be in conformance with the requirements applicable to the higher strength group.

^b Match API standard 2B (fabricated tubes) according to steel used.

^c When welds are to be stress-relieved, the deposited weld metal shall not exceed 0.05% vanadium.

^d Only low-hydrogen electrodes shall be used when welding ASTM A 36 or ASTM A 709 Grade 36 steel more than 1 in [25 mm] thick for cyclically loaded structures.

^e Special welding materials and WPS (e.g., E80XX-X low-alloy electrodes) may be required to match the notch toughness of base metal (for applications involving impact loading or low temperature), or for atmospheric corrosion and weathering characteristics (see 3.7.3).

^f Filler metals of alloy group B3, B3L, B4, B4L, B5, B5L, B6, B6L, B7, B7L, B8, B8L, B9, or any BXH grade in AWS A5.5, A5.23, A5.28, or A5.29 are not prequalified for use in the as-welded condition.

^g AWS A5M (SI Units) electrodes of the same classification may be used in lieu of the AWS A5 (U.S. Customary Units) electrode classification.

^h The heat input limitations of 5.7 shall not apply to ASTM A 913 Grade 60 or 65.

APPENDIX XV

MINIMUM PREHEAT AND INTERPASS TEMPERATURE^{c, d}

C a t e g o r y	Steel Specification		Welding Process	Thickness of Thickest Part at Point of Welding		Minimum Preheat and Interpass Temperature			
				in	mm	°F	°C		
A	ASTM A 36 ^b		ASTM A 516	Grades 55 & 60	Shielded metal arc welding with other than low-hydrogen electrodes	Up to 3/4 incl.	Up to 19 incl.	None ^a	
	ASTM A 53	Grade B	ASTM A 524	Grades I & II		Over 3/4 thru 1-1/2 incl.	Over 19 thru 38 incl.	150	66
	ASTM A 106	Grade B	ASTM A 529						
	ASTM A 131	Grades A, B, CS, D, DS, E	ASTM A 570	All grades					
	ASTM A 139	Grade B	ASTM A 573	Grade 65					
	ASTM A 381	Grade Y35	ASTM A 709	Grade 36 ²					
	ASTM A 500	Grade A	API 5L	Grade B					
	ASTM A 501	Grade B	API 5LX	Grade X42					
		ABS	Grades A, B, D, CS, DS						
			Grade E			Over 2-1/2	Over 64	300	150
B	ASTM A 36 ^b		ASTM A 570	All grades	Shielded metal arc welding with low-hydrogen electrodes, submerged arc welding, ^b gas metal arc welding, flux cored arc welding	Up to 3/4 incl.	Up to 19 incl.	None ^a	
	ASTM A 53	Grade B	ASTM A 572	Grades 42, 50					
	ASTM A 106	Grade B	ASTM A 573	Grade 65					
	ASTM A 131	Grades A, B, CS, D, DS, E	ASTM A 588						
		AH 32 & 36	ASTM A 595	Grades A, B, C					
		DH 32 & 36	ASTM A 606						
		EH 32 & 36	ASTM A 607	Grades 45, 50, 55					
	ASTM A 139	Grade B	ASTM A 618						
	ASTM A 242		ASTM A 633	Grades A, B					
	ASTM A 381	Grade Y35	ASTM A 709	Grades C, D					
	ASTM A 441		ASTM A 709	Grades 36, 50, 50W					
	ASTM A 500	Grade A	API 5L	Grade B					
		Grade B	API 5LX	Grade X42					
	ASTM A 501		API Spec. 2H						
ASTM A 516	Grades 55, 60, 65, & 70	ABS	Grades AH 32 & 36						
ASTM A 524	Grades I & II		DH 32 & 36						
ASTM A 529			EH 32 & 36						
ASTM A 537	Classes 1 & 2	ABS	Grades A, B, D, CS, DS						
			Grade E						
						Over 2-1/2	Over 64	225	107

(Continued)

APPENDIX XV (Continued)

Category	Steel Specification	Welding Process	Thickness of Thickest Part at Point of Welding		Minimum Preheat and Interpass Temperature	
			in	mm	°F	°C
C	ASTM A 572 Grades 60, 65 ASTM A 633 Grade E API 5LX Grade X52	Shielded metal arc welding with low hydrogen electrodes, submerged arc welding, gas metal arc welding, or flux cored arc welding	Up to 3/4 incl.	Up to 19 incl.	50	10
			Over 3/4 thru 1-1/2 incl.	Over 19 thru 38 incl.	150	66
			Over 1-1/2 thru 2-1/2 incl.	Over 38 thru 64 incl.	225	107
			Over 2-1/2	Over 64	300	150
D	ASTM A 514 ASTM A 517 Grades 100 & 100W ASTM A 709	Shielded metal arc welding with low hydrogen electrodes, submerged arc welding with carbon or alloy steel wire, neutral flux, gas metal arc welding, flux cored arc welding	Up to 3/4 incl.	Up to 19 incl.	50	10
			Over 3/4 thru 1-1/2 incl.	Over 19 thru 38 incl.	125	50
			Over 1-1/2 thru 2-1/2 incl.	Over 3 thru 64 incl.	175	80
			Over 2-1/2	Over 64	225	107

^a When the base metal temperature is below 32°F [0°C], the base metal shall be preheated to at least 70°F [20°C] and this minimum temperature maintained during welding.

^b Only low hydrogen electrodes shall be used when welding A 36 or A 709 Grade 36 steel more than 1 in [25 mm] thick for bridges.

^c Welding shall not be done when the ambient temperature is lower than 0°F [-18°C]. A temperature of 0°F [-18°C] does not mean the ambient environmental temperature but the temperature in the immediate vicinity of the weld. The ambient environmental temperature may be below 0°F [-18°C], but a heated structure or shelter around the area being welded could maintain the temperature adjacent to the weldment at 0°F [-18°C] or higher.

When the base metal is below the temperature listed for the welding process being used and the thickness of material being welded, it shall be preheated (except as otherwise provided) in such manner that the surfaces of the parts on which weld metal is being deposited are at or above the specified minimum temperature for a distance equal to the thickness of the part being welded, but not less than 3 in [76 mm] in all directions from the point of welding.

Preheat and interpass temperatures must be sufficient to prevent crack formation. Temperature above the minimum shown may be required for highly restrained welds. For ASTM A 514, A 517, and A 709 Grades 100 and 100W steel, the maximum preheat and interpass temperature shall not exceed 400°F [205°C] for thickness up to 1-1/2 in [38 mm] inclusive, and 450°F [230°C] for greater thickness. Heat input when welding ASTM A 514, A 517, and A 709 Grades 100 and 100W steel shall not exceed the steel producer's recommendations. ASTM A 514 and A 517 materials are not recommended to be post weld heat treated.

^d In joints involving combinations of base metals, preheat shall be as specified for the higher strength steel being welded.

APPENDIX XVI

RADIOGRAPHIC TESTING

1. Welding Procedure Qualification

- 1.1 After meeting visual inspection acceptance criteria and before preparing mechanical test specimens, the procedure qualification test specimens, the qualification test plate, pipe, or tubing shall be nondestructively tested for soundness.
- 1.2 Either radiographic or ultrasonic testing shall be used. The entire length of the weld in the test plates, except the discard lengths at each end, shall be examined.
- 1.3 For acceptable qualification, the weld, as revealed by radiographic or ultrasonic testing, shall conform to the requirements of paragraph 3.

2. Welder Performance Qualification

- 2.1 Except for joints welded by GMAW-S, radiographic examination of a welder or welding operator qualification test plate or test pipe may be made in lieu of guided bend tests.
 - 2.1.1 If RT is used in lieu of the prescribed bend tests, the weld reinforcement need not be ground or otherwise smoothed for inspection unless its surface irregularities or juncture with the base metal would cause objectionable weld discontinuities to be obscured in the radiograph. If the backing is removed for radiography, the root shall be ground flush with the base metal.
 - 2.1.2 For welder qualification, exclude 1-1/4 in [32 mm] at each end of the weld from evaluation in the plate test; for welding operator qualification exclude 3 in [75 mm] at each end of the test plate length. Welded test pipe or tubing 4 in [100 mm] in diameter or larger shall be examined for a minimum of one-half of the weld perimeter selected to include a sample of all positions welded.
 - 2.1.3 For acceptable qualification, the weld, as revealed by the radiograph, shall conform to the requirements of 3.1.

3. Radiographic Inspection

Discontinuities other than cracks shall be evaluated on the basis of being either elongated or rounded. Regardless of the type of discontinuity, an elongated discontinuity is one in which its length exceeds three times its width. A rounded discontinuity is one in which its length is three times its width or less and may be round or irregular and may have tails.

- 3.1 **Acceptance Criteria for Cyclically Loaded Nontubular Connections.** Welds that are subject to radiographic testing in addition to visual inspection shall have no cracks and shall be unacceptable if the radiographic testing shows any of the types of discontinuities listed in 3.1.1 and 3.1.2.

APPENDIX XVI (Continued)

- 3.1.1 For welds subjected to tensile stress under any condition of loading, the greatest dimension of any porosity or fusion-type discontinuity that is $1/16$ in [2 mm] or larger in greatest dimension shall not exceed the size B indicated in Figure 6.4 for the weld size involved. The distance from any porosity or fusion-type discontinuity described above to another such discontinuity, to an edge, or to the toe or root of any intersecting flange-to-web weld shall be not less than the minimum clearance allowed, C, indicated in Figure 6.4 (see page 3-49), for the size of discontinuity under examination.
- 3.1.2 Independent of the requirements of 3.1.1, discontinuities having a greatest dimension of less than $1/16$ in [2 mm] shall be unacceptable if the sum of their greatest dimensions exceeds $3/8$ in [10 mm] in any linear inch [25.4 mm] of weld.

APPENDIX XVI (Continued)

HOLE-TYPE IMAGE QUALITY INDICATOR (IQI) REQUIREMENTS

Nominal Material Thickness ^a Range, in	Nominal Material Thickness ^a Range, mm	Source Side		Film Side ^b	
		Designation	Essential Hole	Designation	Essential Hole
Up to 0.25 incl.	Up to 6 incl.	10	4T	7	4T
Over 0.25 to 0.375	Over 6 through 10	12	4T	10	4T
Over 0.375 to 0.50	Over 10 through 12	15	4T	12	4T
Over 0.50 to 0.625	Over 12 through 16	15	4T	12	4T
Over 0.625 to 0.75	Over 16 through 20	17	4T	15	4T
Over 0.75 to 0.875	Over 20 through 22	20	4T	17	4T
Over 0.875 to 1.00	Over 22 through 25	20	4T	17	4T
Over 1.00 to 1.25	Over 25 through 32	25	4T	20	4T
Over 1.25 to 1.50	Over 32 through 38	30	2T	25	2T
Over 1.50 to 2.00	Over 38 through 50	35	2T	30	2T
Over 2.00 to 2.50	Over 50 through 65	40	2T	35	2T
Over 2.50 to 3.00	Over 65 through 75	45	2T	40	2T
Over 3.00 to 4.00	Over 75 through 100	50	2T	45	2T
Over 4.00 to 6.00	Over 100 through 150	60	2T	50	2T
Over 6.00 to 8.00	Over 150 through 200	80	2T	60	2T

^aSingle-wall radiographic thickness (for tubulars).

^bApplicable to tubular structures only.

WIRE IMAGE QUALITY INDICATOR (IQI) REQUIREMENTS

Nominal Material Thickness ^a Range, in	Nominal Material Thickness ^a Range, mm	Source Side		Film Side ^b	
		Maximum Wire Diameter		Maximum Wire Diameter	
		in	mm	in	mm
Up to 0.25 incl.	Up to 6 incl.	0.010	0.25	0.008	0.20
Over 0.25 to 0.375	Over 6 to 10	0.013	0.33	0.010	0.25
Over 0.375 to 0.625	Over 10 to 16	0.016	0.41	0.013	0.33
Over 0.625 to 0.75	Over 16 to 20	0.020	0.51	0.016	0.41
Over 0.75 to 1.50	Over 20 to 38	0.025	0.63	0.020	0.51
Over 1.50 to 2.00	Over 38 to 50	0.032	0.81	0.025	0.63
Over 2.00 to 2.50	Over 50 to 65	0.040	1.02	0.032	0.81
Over 2.50 to 4.00	Over 65 to 100	0.050	1.27	0.040	1.02
Over 4.00 to 6.00	Over 100 to 150	0.063	1.60	0.050	1.27
Over 6.00 to 8.00	Over 150 to 200	0.100	2.54	0.063	1.60

^aSingle-wall radiographic thickness (for tubulars).

^bApplicable to tubular structures only.

APPENDIX XVI (Continued)

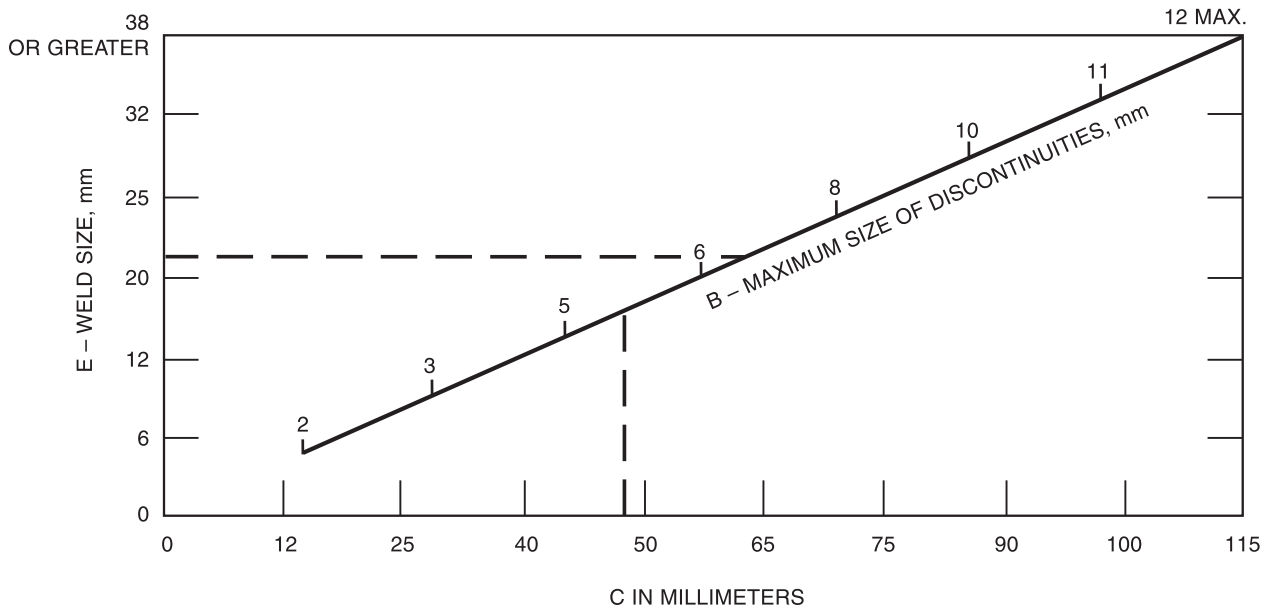
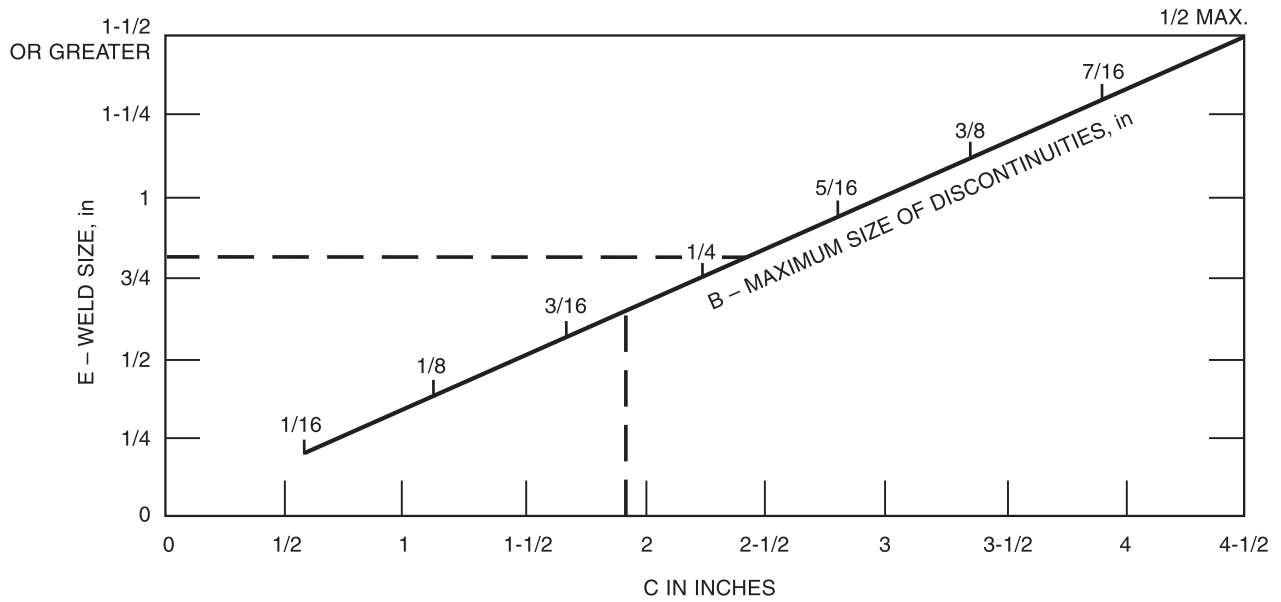

Notes:

1. To determine the maximum size of discontinuity allowed in any joint or weld size, project E horizontally to B.
2. To determine the minimum clearance allowed between edges of discontinuities of any size, project B vertically to C.
3. See Legend below for definitions.

Figure 6.4—Weld Quality Requirements for Discontinuities Occurring in Cyclically Loaded Nontubular Tension Welds (Limitations of Porosity and Fusion Discontinuities)

APPENDIX XVI (Continued)

Legend

Dimensions of Discontinuities

B = Maximum allowed dimension of a radiographed discontinuity.

L = Largest dimension of a radiographed discontinuity.

L' = Largest dimension of adjacent discontinuities.

C = Minimum clearance measured along the longitudinal axis of the weld between edges of porosity or fusion-type discontinuities (larger of adjacent discontinuities governs), or to an edge or an end of an intersecting weld.

C₁ = Minimum allowed distance between the nearest discontinuity to the free edge of a plate or tubular, or the intersection of a longitudinal weld with a girth weld, measured parallel to the longitudinal weld axis.

W = Smallest dimension of either of adjacent discontinuities.

Material Dimensions

E = Weld size.

T = Plate or pipe thickness for CJP groove welds.

Definitions of Discontinuities

- An elongated discontinuity shall have the largest dimension (L) exceed 3 times the smallest dimension.
 - A rounded discontinuity shall have the largest dimension (L) less than or equal to 3 times the smallest dimension.
 - A cluster shall be defined as a group of nonaligned, acceptably-sized, individual adjacent discontinuities with spacing less than the minimum allowed (C) for the largest individual adjacent discontinuity (L'), but with the sum of the greatest dimensions (L) of all discontinuities in the cluster equal to or less than the maximum allowable individual discontinuity size (B). Such clusters shall be considered as individual discontinuities of size L for the purpose of assessing minimum spacing.
 - Aligned discontinuities shall have the major axes of each discontinuity approximately aligned.
-

APPENDIX XVII

FACE AND ROOT BEND SPECIMENS

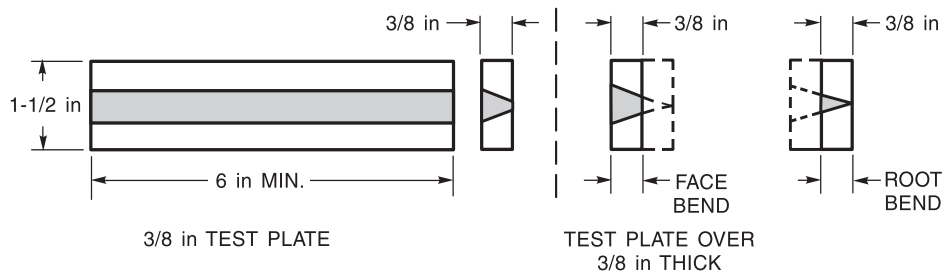

(1) LONGITUDINAL BEND SPECIMEN

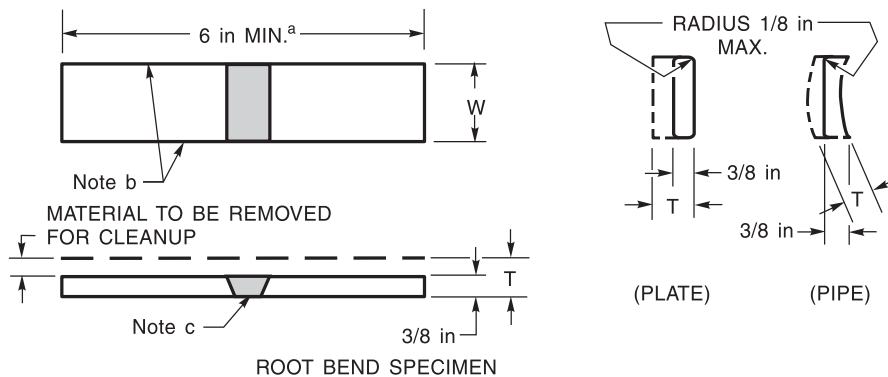
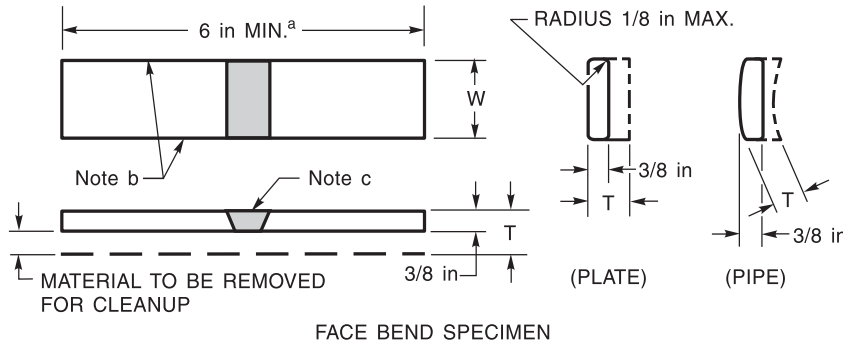

(2) TRANSVERSE BEND SPECIMEN

Dimensions	
Test Weldment	Test Specimen Width, W in
Plate	1-1/2
Test pipe or tube ≤ 4 inches in diameter	1
Test pipe or tube > 4 inches in diameter	1-1/2

^a A longer specimen length may be necessary when using a wraparound type bending fixture or when testing steel with a yield strength of 90 ksi [620 MPa] or more.

^b These edges may be thermal-cut and may or may not be machined.

^c The weld reinforcement and backing, if any, shall be removed flush with the surface of the specimen. If a recessed backing is used, this surface may be machined to a depth not exceeding the depth of the recess to remove the backing; in such a case, the thickness of the finished specimen shall be that specified above. Cut surfaces shall be smooth and parallel.

Notes:

1. T = plate or pipe thickness.

2. When the thickness of the test plate is less than 3/8 in [10 mm], the nominal thickness shall be used for face and root bends.

